

INSTALLATION, SERVICE AND MAINTENANCE INSTRUCTIONS

TANK BOTTOM VALVE

INNOVA F

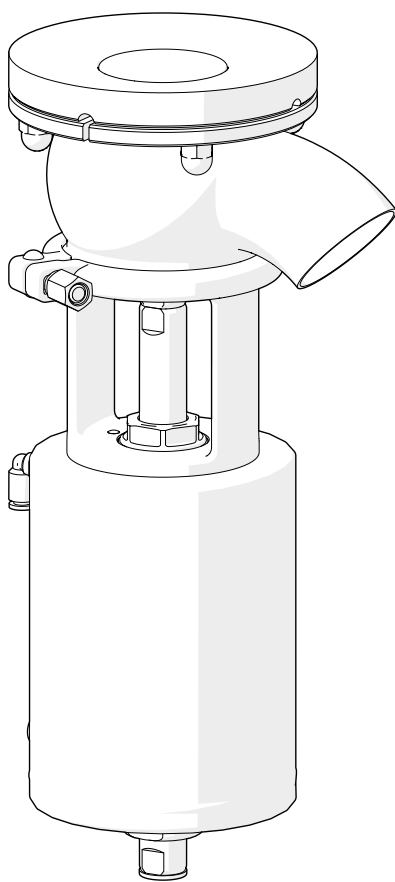

10.248.32.0032



Original Instructions

10.248.30.12EN

(0) 2024/09

EC Declaration of Conformity



INOXPA S.A.U.

Telers, 60
17820 - Banyoles (Spain)

hereby declare under our sole responsibility that the

Machine: **BOTTOM TANK VALVE**

Model: **INNOVA**

Type: **F**

Size: **DN 25 - DN 100 / OD 1" - OD 4"**

Serial number: **IXXXXXXXXXX to IXXXXXXXXXX**
XXXXXXXXXXIINXXX to XXXXXXXXXXXIINXXX

fulfills all the relevant provisions of the following directive:

Machinery Directive 2006/42/EC¹
Pressure Equipment Directive 2014/68/EU^{2,3}
Regulation (EC) n° 1935/2004
Regulation (EC) n° 2023/2006

and with the following harmonized standards and/or regulations:

EN ISO 12100:2010, EN ISO 13732-1:2008, EN 1672-2:2005+A1:2009,
EN ISO 14159:2008, EN 12266-1:2012, EN 19:2016

The technical file has been prepared by the signer of this document.

David Reyero Brunet
Technical Office Manager
18th July 2024



Document: 10.248.30.10EN

Revision: (0) 2024/07

¹INNOVA F with pneumatic actuator

²INNOVA F with manual or pneumatic actuator

³DN≤25 Designed and manufactured in accordance with the sound engineering practice
DN>25 Class I equipment. Conformity assessment procedure used: Module A

Declaration of Conformity



INOXPA S.A.U.

Telers, 60
17820 - Banyoles (Spain)

hereby declare under our sole responsibility that the

Machine:	BOTTOM TANK VALVE
Model:	INNOVA
Type:	F
Size:	DN 25 - DN 100 / OD 1" - OD 4"
Serial number:	IXXXXXXXXXX to IXXXXXXXXXX XXXXXXXXXXIINXXX to XXXXXXXXXXXIINXXX

fulfills all the relevant provisions of these regulations:

Supply of Machinery (Safety) Regulations 2008¹
Pressure Equipment (Safety) Regulations 2016^{2,3}

and with the following designated standards:

**EN ISO 12100:2010, EN ISO 13732-1:2008, EN 1672-2:2005+A1:2009,
EN ISO 14159:2008, EN 12266-1:2012, EN 19:2016**

The technical file has been prepared by the signer of this document.

A handwritten signature in black ink, appearing to read "David Reyer Brunet".

David Reyer Brunet
Technical Office Manager
15th July 2024



Document: 10.248.30.11EN

Revision: (0) 2024/07

¹INNOVA F with pneumatic actuator

²INNOVA F with manual or pneumatic actuator

³DN≤25 Designed and manufactured in accordance with the sound engineering practice
DN>25 Class I equipment. Conformity assessment procedure used: Module A

1. Table of Contents

1. Table of Contents	
2. Generalities	
2.1. Instructions manual	5
2.2. Compliance with the instructions	5
2.3. Warranty	5
3. Safety	
3.1. Warning symbols.....	6
3.2. General safety instructions	6
4. General Information	
4.1. Description	7
4.2. Application.....	7
5. Installation	
5.1. Reception of the valve.....	8
5.2. Transport and storage	8
5.3. Identification of the valve.....	8
5.4. Location	10
5.5. Direction of flow.....	10
5.6. General installation	10
5.7. Checking and review	11
5.8. Welding	11
5.9. Valve configuration with actuator.....	12
5.10. Actuator air connection.....	12
6. Start-up	
7. Operating problems	
8. Maintenance	
8.1. General considerations	15
8.2. Maintenance	15
8.3. Cleaning.....	16
8.4. Disassembly and assembly of the valve	17
8.5. Replacing the seat seal	20
8.6. Actuator configuration.....	20
8.7. Disassembly and assembly of adapter kit of the control head.....	21
9. Technical Specifications	
9.1. Valve	22
9.2. Actuator.....	22
9.3. Materials	22
9.5. Sizes available.....	22
9.4. Weights	22
9.6. Dimensions	23
9.7. Exploded drawing and parts list of the valve	25

2. Generalities

2.1. INSTRUCTIONS MANUAL

This manual contains information about the reception, installation, operation, assembly and maintenance of the tank bottom valve INNOVA F.

Carefully read the instruction prior to starting the valve, familiarize yourself with the installation, operation and correct use of the valve and strictly follow the instructions. These instructions should be kept in a safe location near the installation area.

The information published in the instruction manual is based on updated data.

INOXPA reserves the right to modify this instruction manual without prior notice.

2.2. COMPLIANCE WITH THE INSTRUCTIONS

Not following the instructions may impose a risk for the operators, the environment and the machine, and may cause the loss of the right to claim damages.

This non-compliance may cause the following risks:

- failure of important machine/plant functions,
- failure of specific maintenance and repair procedures,
- possible electrical, mechanical and chemical hazards,
- risk to the environment due to the type of substances released.

2.3. WARRANTY

The conditions of the warranty are specified in the General Sales Condition that has been delivered at the time of placing your order.



The machine may not undergo any modification without prior approval from the manufacturer.

For your safety, only use original spare parts and accessories. The usage of other parts will relieve the manufacturer of any liability.

Changing the service conditions can only be carried out with prior written authorization from INOXPA.

The non-compliance of the prescribed indications in this manual means misuse of this gear on the technical side and the personal safety and this exempts INOXPA of all responsibility in case of accidents and personal injuries and/or property damage. Also, excluded from the warranty all breakdowns caused by improper use of the gear.

Please do not hesitate to contact us in case of doubts or if further explanations are required regarding specific data (adjustments, assembly, disassembly, etc.).

3. Safety

3.1. WARNING SYMBOLS



Safety hazard for people in general and/or equipment

ATTENTION

Important instruction to prevent damage to the equipment and/or its function

3.2. GENERAL SAFETY INSTRUCTIONS



Read the instruction manual carefully before installing and starting the valve. Contact INOXPA in case of doubt.

3.2.1. During installation



Always take into account the [Technical Specifications of chapter 9](#).

The installation and use of the valve should always be in accordance with applicable regulations regarding health and safety.

Before starting up the valve, check that it is assembled correctly and its shaft is perfectly aligned. Incorrect alignment and/or excessive stress during coupling can cause serious mechanical problems in the valve.

3.2.2. During operation



Always take into account the [Technical Specifications of chapter 9](#).

NEVER exceed the specified limit values.

NEVER touch the valve and/or piping that is in contact with the fluid during operation. If the process involves hot products there is a risk of burns.

The valve contains parts that move in a linear fashion. Do not place hands or fingers in the valve closing area. This can cause serious injury.

3.2.3. During maintenance



Always take into account the [Technical Specifications of chapter 9](#).

NEVER disassemble or remove the valve until the pipes have been emptied. Bear in mind that the fluid in the pipe may be hazardous or extremely hot. Consult the regulations in effect in each country for these cases.

Inside the actuator there is a spring with an applied load. The steps specified in this manual must be followed when performing maintenance operations to avoid injury.

Do not leave loose parts on the floor.

4. General Information

4.1. DESCRIPTION

The tank bottom valve INNOVA F is a pneumatically actuated single seat valve designed to drain the fluid of the tank in hygienical applications.

4.2. APPLICATION

The INNOVA F valve are used for applications in dairy, food, beverage, pharmaceutical and chemical industries.

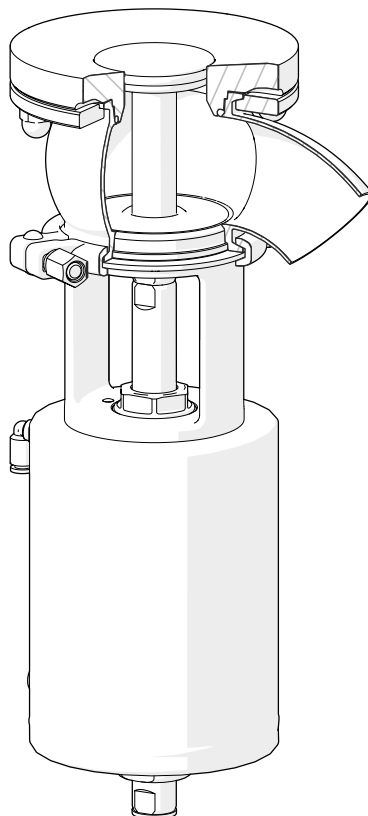

10.248.32.0040

5. Installation

5.1. RECEPTION OF THE VALVE



INOXPA is not liable for any deterioration of the material caused by its transport or unpacking.

When receipt the valve, check to see whether all the parts listed on the delivery slip are present:

- complete valve,
- its components if any are supplied,
- quick installation guide with access to the complete instructions manual.

INOXPA inspects all its equipment before packaging. However, it cannot guarantee that the merchandise arrives at the user intact.

When unpacking the valve:

- remove any possible traces of packaging from the valve or its parts,
- inspect the valve or the parts that comprise it for possible damage incurred during shipping,
- take all possible precautions against damage to the valve and its components.

5.2. TRANSPORT AND STORAGE



The buyer or user shall be liable for assembly, installation, start-up and operation of the valve.

Take all possible precautions when transport and storage the valve to avoid damage it and its components.

5.3. IDENTIFICATION OF THE VALVE

Each valve is inscribed with its fabrication number. Indicate the fabrication number on all documents to refer to the valve.

 	
INOXPA S.A.U. C. TELERS, 60 - 17820 BANYOLES GIRONA (SPAIN) . www.inoxpa.com	
Type Serial Air	Size Year

10.251.32.0043

WB	F	L	0	-	0	06	52	050	12	0	SB	
											Flange	
											SB without flange	
											- with flange	
											Surface finish	
											0 ID Ra ≤ 0,8	
											1 ID Ra ≤ 0,5	
											Actuator	
											11 T1 A/S NC	
											12 T2 A/S NC	
											13 T3 A/S NC	
											14 T4 A/S NC	
											21 T1 A/S NO	
											22 T2 A/S NO	
											23 T3 A/S NO	
											24 T4 A/S NO	
											31 T1 A/A	
											32 T2 A/A	
											33 T3 A/A	
											34 T4 A/A	
											Size	
											025 DN 25, OD 1"	065 DN 65
											040 DN 40, OD 1½"	076 OD 3"
											050 DN 50, OD 2"	080 DN 80
											063 OD 2½"	100 DN 100, OD 4"
											Seals	
											43 HNBR	
											52 EPDM	
											78 FPM	
											Material	
											06 1.4404 (AISI 316L)	
											Connection	
											0 Soldar	
											1 Macho	
											7 Clamp	
											Standard pipe	
											0 DIN	
											1 OD	
											Body configuration	
											L,T 1 body	
											Type	
											F tank bottom valve	
											Familia producto	
											WB INNOVA valve	

5.4. LOCATION

Place the valve leaving enough space around it to realize easily the dismantling, the inspection and the review the valve as well as in order to access to the actuator air connection's device for valves with automatic actuation even when the valve is operating. Consult in chapter 5.8. [Welding](#) the required minimum distances. The installation should allow that the removable parts are could remove easily.

5.5. DIRECTION OF FLOW

The recommended direction of flow is contrary to the movement of the valve closing so that when the valve is closing, the valve will always work against the fluid pressure. Follow these indications to avoid the water hammer, which can occur when valves close, minimising its consequences. The next figures show the recommende direction of flow as well as the direction of closing.

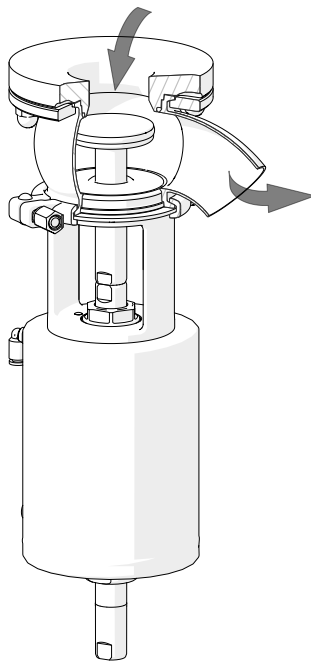

5.6. GENERAL INSTALLATION

After the location of the valve is defined, the valve can be joined to the pipe by welding the valve housing or using fittings.

In case of joining the valve to the pipe by fittings do not forget the seals and tighten the unions properly.

If instead, the valve is joined by welding, before starting to weld the valve bodies to the pipe disassemble the valve to prevent damage to the joints, following the instructions in chapter 8.4. [Disassembly and assembly the valve.](#)

During installation, the valve avoids using excessive force and pay special attention to:

- vibrations that may be produced on the facility,
- hermal dilation that the pipe may undergo when hot fluids are circulating,
- the weight that the pipe can support,
- excessive welding current.

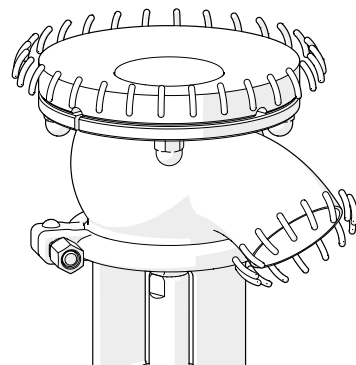

When you weld the flange to the tank, the grooves of the flange (A) should fit with the valve body connection.

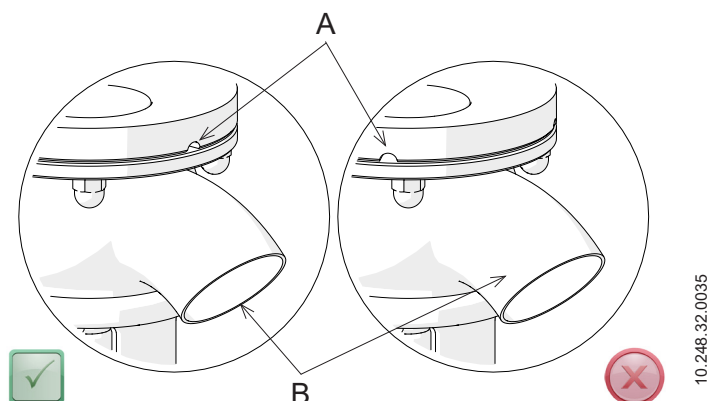

5.7. CHECKING AND REVIEW

Perform the following checks before using the valve:

- check that the clamps and nuts are tightened,
- open and close the valve, applying compressed air to the actuator, several times to make sure it operates correctly and that the shaft seal is coupled smoothly to the valve body.

5.8. WELDING



Welding work should only be done by qualified persons who are trained and equipped with the necessary equipment to perform this kind of work.

To perform the welding works:

- disassemble the valve as indicated in chapter 8.4. [Disassembly and assembly the valve](#),
- weld the valve body to the pipes maintaining the distance indicated in the following table. This will allow for the disassembly of the valve, doing the subsequent reviews and changing the necessary valve pieces like seals, bushings, etc.

	DIN - OD	A [mm]	B [mm]	C [mm]
A/S	25 - 1"	310	450	90
	40 - 1½"	310	460	110
	50 - 2"	360	510	130
	65 - 2½"	380	530	160
	80 - 3"	380	530	180
	100 - 4"	410	560	210
A/A	25 - 1"	280	420	90
	40 - 1½"	280	430	110
	50 - 2"	310	460	130
	65 - 2½"	330	480	160
	80 - 3"	330	480	180
	100 - 4"	360	510	210

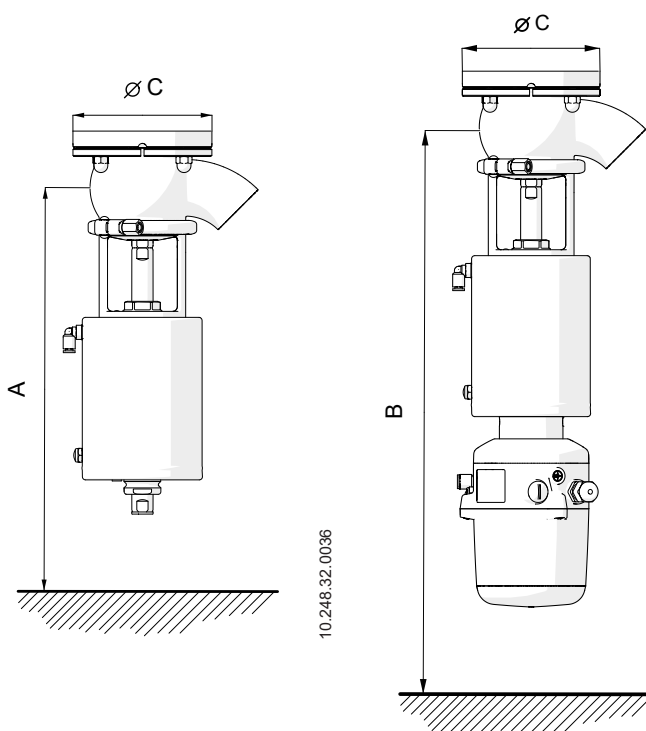

5.9. VALVE CONFIGURATION WITH ACTUATOR

The standard configuration of the valves is NC (normally closed).

It is possible to convert the valve to NO (normally open) simply by turning the valve actuator, according to chapter 8.6. [Actuator configuration](#).



Always disconnect the compressed air before starting to disassemble the valve.
Never disassemble the valve clamps directly without reading the instructions carefully, since the actuator contains a spring inside it with an applied load.
Valve and actuator assembly and disassembly should only be done by qualified persons.

5.10. ACTUATOR AIR CONNECTION

To perform the air connection to the actuator:

- connect and check the air connections (G 1/8" thread for tubing Ø6 mm)
- mind the quality of the compressed air according to the specifications described in chapter 9. [Technical Specifications](#).

Depending on the actuator configuration, the actuator can have one or two air connections.

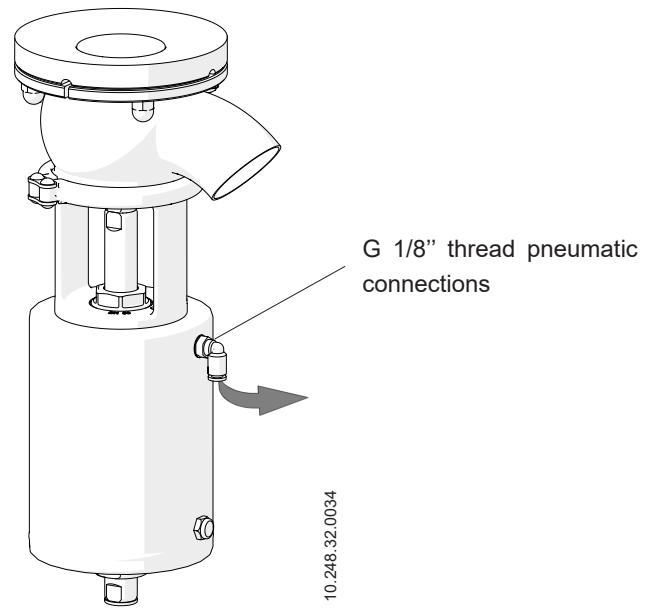

6. Start-up



Read carefully the instructions in chapter [5. Installation](#) before start-up the valve.



Before start-up, the persons in charge must be duly informed about how the valve works and the safety instructions to follow. This instruction manual will be available to personnel at all times.

Before putting the valve or the actuator into service the following must be taken into consideration:

- check that the piping and valve are completely free of possible traces of welding slag or other foreign particles. Clean the system if necessary,
- check to make sure the valve moves smoothly. If necessary, lubricate it with special grease or soapy water,
- check for possible leaks, and make sure the pipes and their connections are sealed and do not have any leaks,
- if the valve has been supplied with an actuator, make sure that the alignment of the valve shaft and the actuator shaft enables smooth movement,
- check that the compressed air pressure at the inlet of the actuator matches what is indicated in chapter [9. Technical Specifications](#),
- consider the quality of the compressed air, according to the specifications described in chapter [9. Technical Specifications](#),
- activate the valve.



Do not modify the operating parameters for which the valve has been designed without prior written authorisation from INOXPA.

Do not touch the moving parts of the coupling between the actuator and the valve when the actuator is connected to the compressed air supply.



¡Burn hazard! Do not touch the valve or pipes when the hot fluids are circulating or when cleaning and/or sterilization are being carried out.

7. Operating problems

Water hammer	
Valve does not open/close	
Internal leak of product (valve closed)	
Jerky valve operation	
POSSIBLE CAUSES	SOLUTIONS
<ul style="list-style-type: none"> The seal or guide bushing is worn, deteriorated or has gotten stuck 	Replace the seals. Replace the seals with ones made of a different material or grade that is more appropriate for the product. Lubricate with soapy water or a lubricant that is compatible with the seal material and the product.
<ul style="list-style-type: none"> Insufficient air pressure 	Replace the actuator with a larger one. Increase the compressed air pressure.
<ul style="list-style-type: none"> Incorrect configuration of the head control 	Adjust the parameters according to the valve needs.
<ul style="list-style-type: none"> Normal seal wear 	Replace the seals.
<ul style="list-style-type: none"> Premature wear of the seal/affected by the product 	Replace the seals with ones made of a different material or grade that is more appropriate for the product. Reduce the pressure in the line. Lower the operating temperature.
<ul style="list-style-type: none"> Product residue has deposited on the valve seat and/or plug 	Clean frequently.
<ul style="list-style-type: none"> Excess product pressure 	Replace the actuator with a larger one. Connect an auxiliary compressed air nipple on the side of the spring to offset the excess pressure without exceeding 4 bar. Reduce the product pressure.
<ul style="list-style-type: none"> Loss of seal (vibrations) 	Tighten loose parts.
<ul style="list-style-type: none"> Product pressure exceeds the actuator specifications 	Replace the actuator with a larger one. Reduce the product pressure. Use auxiliary air on the spring side.
<ul style="list-style-type: none"> Warping of seals 	Replace the seals with ones of a different quality if they have deteriorated prematurely.
<ul style="list-style-type: none"> Actuator spring is in poor condition and/or suck (dirty) 	Replace the spring or clean.
<ul style="list-style-type: none"> The direction of flow is the same as the direction of closing 	The direction of flow should go against the direction of closing. Choke the air discharge to reduce the pressure.

8. Maintenance

8.1. GENERAL CONSIDERATIONS

This valve, just like any other machine, requires maintenance. The instructions in this chapter cover the maintenance of the valve, the identification and replacement of the spare parts and the disassembly and assembly of the valve. The instructions are aimed at maintenance personnel and those responsible for the supply of spare parts.



Read carefully the chapter [9. Technical Specifications](#).

Maintenance work should only be done by qualified persons who are trained and equipped with the necessary equipment to perform this kind of work.

All replaced material should be duly disposed or recycled according to the directives in effect in each area.

Make sure that the pipes are not under pressure before starting maintenance work..

8.2. MAINTENANCE

To perform maintenance properly is recommended:

- periodic inspection of the valve and its components,
- keeping an operational record of each valve writing down any problems,
- always having spare replacement seals in stock.

Pay special attention to the hazard warnings indicated in this manual during the performance of the maintenance work.



The valve and the pipes must never be under pressure during maintenance.

⚠ Burn hazard! Do not touch the valve or the pipes when hot fluids are circulating or when cleaning and/or sterilization are being carried out.

The time interval between each preventive maintenance may vary in accordance with the work conditions to which the valve is subject: temperature, pressure, number of operations per day, type of cleaning solutions used, etc.

8.2.1. Maintenance of the seals

REPLACING SEAL	
Preventive maintenance	Replace after 12 months
Maintenance after a leak	Replace at the end of the process
Planned maintenance	Regularly check the absence of leaks and the smooth operation of the valve. Keep a record of the valve's maintenance. Use statistics for planning inspections.
Lubrication	During assembly, apply lubricants that are suitable with the material of which the seat seal is made. See the following table.

SEAL COMPONENT	LUBRICANT	NLGI DIN 51818 Class
HNBR / FPM	klübersynth UH 1 64-2403	3
EPDM / HNBR / FPM	PARALIQ GTE 703	3

8.2.2. Storage

The valves should be stored in a closed area under the following conditions:

- temperature between 15°C y 30°C,
- air humidity < 60%

Storage of the equipment outdoors is NOT allowed.

8.2.3. Spare parts

To request spare parts is necessary to indicate the type of valve, the size, the fabrication number, the position and the description of the part which can be found in chapter 9. [Technical Specifications](#).

8.3. CLEANING



The use of aggressive cleaning products such as caustic soda and nitric acid may burn the skin.

Wear rubber gloves during all cleaning procedures.

Always wear protective goggles.

8.3.1. CIP (clean-in-place) cleaning

If the valve is installed in a system with a CIP process, its disassembly will not be required. EPDM is the standard seal material that will be used for CIP cleaning, both in alkaline mediums and in acid mediums. The materials of the seal HNBR and FPM are not recommended.

Two types of solutions can be used for CIP processes:

a. alkaline solution: 1% by weight of caustic soda (NaOH) at 70°C (150°F). To make this solution:

1 kg NaOH + 100 l H₂O¹ = cleaning solution

2,2 l NaOH at 33% + 100 l H₂O = cleaning solution

b. acid solution: 0,5% by weight of nitric acid (HNO₃) at 70°C (150°F). To make this solution:

0,7 l HNO₃ at 53% + 100 l H₂O = solución de limpieza

1) only use chlorine-free water to mix with the cleaning agents

ATTENTION



Check the concentration of the cleaning solutions. An incorrect concentrations may lead to the deterioration of the valve seals.

To remove any traces of cleaning products, ALWAYS perform a final rinse with clean water at the end of the cleaning process.



Clean the entire interior and exterior of the valve before starting disassembly and assembly tasks.

8.3.2. Automatic SIP (sterilization-in-place)

Sterilization with steam is applied to all equipment including the pipping.

ATTENTION



Do NOT start the equipment during the sterilization with steam.

The parts and the materials will not be damaged if the indications specified in this manual are observed.

No cold fluid can enter the equipment until the temperature of the equipment is lower than 60°C (140°F).

Maximum conditions during the SIP process with steam or superheated water:

- a. maximum temperature: 140°C / 284°F
- b. maximum time: 30 min
- c. cooling: sterile air or inter gas
- d. materials: EPDM (the materials HNBR and FPM are not recommended)

8.4. DISASSEMBLY AND ASSEMBLY OF THE VALVE



Proceed with caution. Personal injury can occur.

Always disconnect the compressed air before starting to disassemble the valve.

Never disassemble the valve clamps directly without reading the instructions carefully, since the actuator contains a spring inside it with an applied load.

Valve and actuator assembly and disassembly should only be done by qualified persons.

The following tools are needed in order to disassembly and assembly the valve and the drives:

- 15 mm and 17 mm spanners to remove the shaft of the valve of DN25 size,
- two 17 mm spanners to remove the shaft of the valve of DN40 to DN100 size,
- 13 mm spanner for the clamps,
- appropriate tool (not piercing) to mount the seat seals,
- 30 mm socket wrench to remove the lantern.

8.4.1. Disassembly



Place a support under the valve to avoid its possible fall when disassembled.

1. At the NC valves, apply compressed air to the actuator (10) so the valve shaft (08) passes to an open position.
2. Place a support under the valve to avoid its possible fall. Unscrew the blind nuts (26) and extract the half rings (15) that join the valve to the tank.
3. Separate the valve from the flange (02) welded to the tank.
4. Extract the O-ring (20B) and the pins (23) from the flange (02) welded to the tank.
5. Loose and separate the clamp (34).
6. Separate the valve body (01) from the actuator (10) - lantern (21) - valve shaft (08) assembly.
7. Unscrew the valve shaft (08) from the actuator (10) shaft by two spanners.
8. Remove the seat seal (05E) following the instructions of chapter 8.5. [Replacing the seat seal](#).
9. Remove the valve body cap (12), which has been housed in the lantern (21).
10. Remove the guide bushing (17), the shaft seal (05), and the O-ring (20B) from the valve body cap (12).
11. With a socket wrench, loose threaded guide from the actuator (10) to separate de lantern (21) from the actuator (10) and remove the pin (56).
12. At the NC valves, release the compressed air from the actuator (10).

8.4.2. Assembly

1. Place the lantern (21) to the actuator (10) and fix its position with the pin (56).
2. At the NC valves, apply compressed air to the actuator (10).
3. Fix the lantern (21) to the actuator (10) with a socket wrench.
4. Place the guide bushing (17) on the valve body cap (12).
5. Place the shaft seal (05) and the O-ring (20B) on the valve body cap (12).
6. Place the valve body cap (12) in the lantern (21).
7. Mount the seat seal (05E) on the valve shaft (08) following the instructions of chapter 8.5. [Replacing the seat seal](#).
8. Thread the valve shaft (08) with the actuator (10) shaft by two spanners.
9. Place the valve body (01) on the actuator (10) - lantern (21) - valve shaft (08) assembly . The body is steerable 360°, place it according to the needs of the user.
10. Fix the valve body (01) with the clamp (34).
11. Place the O-ring (20B) to the flange (02) welded on the tank.
12. Place the pins (23).
13. Place the valve on the flange (02) welded on the tank.
14. Place the half rings (15) and screw the blind nuts (26) to fix the valve to the flange (02) welded on the tank.
15. At the NC valves, release the compressed air from the actuator (10).

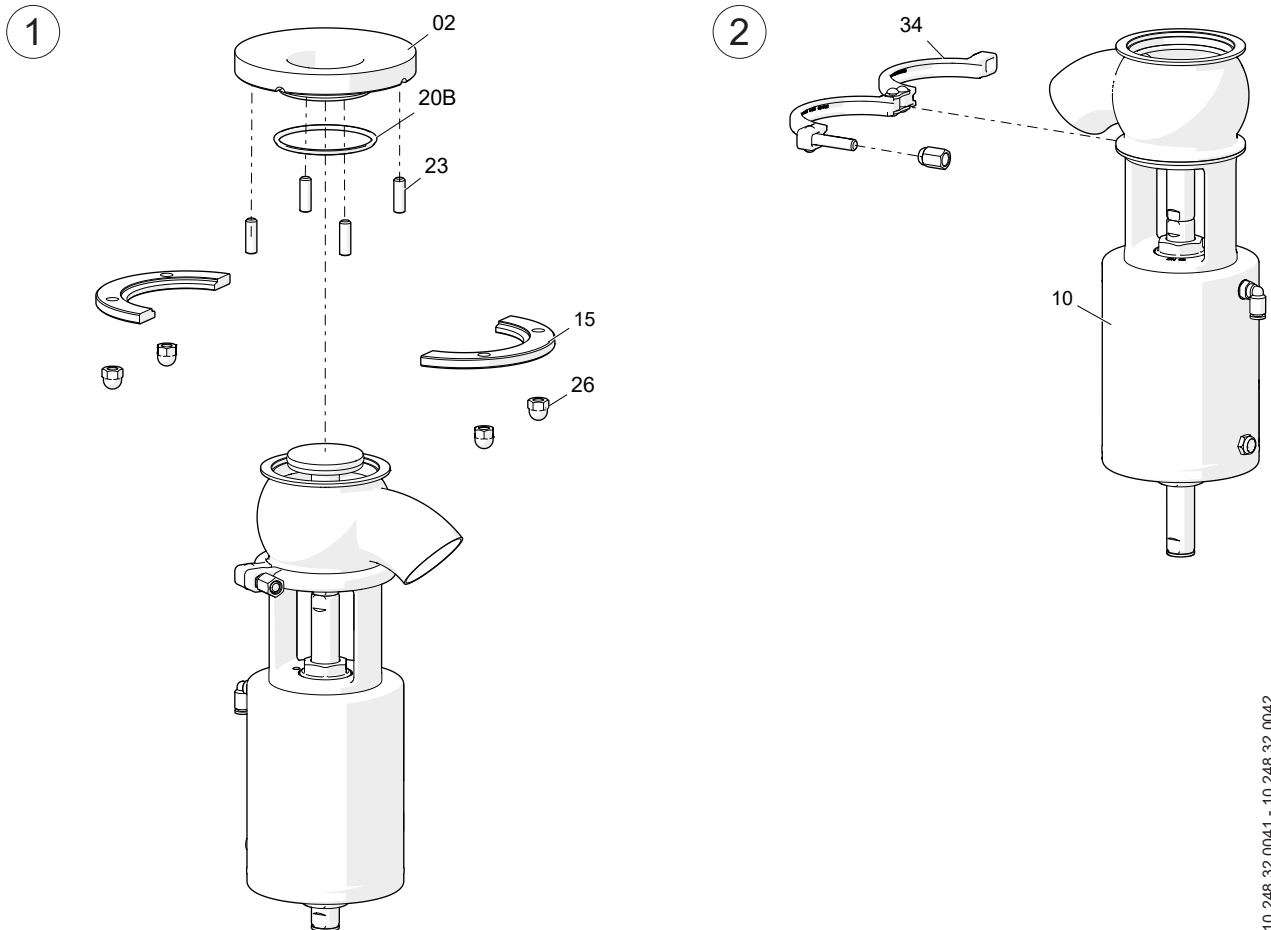

10.248.32.0041 - 10.248.32.0042

3

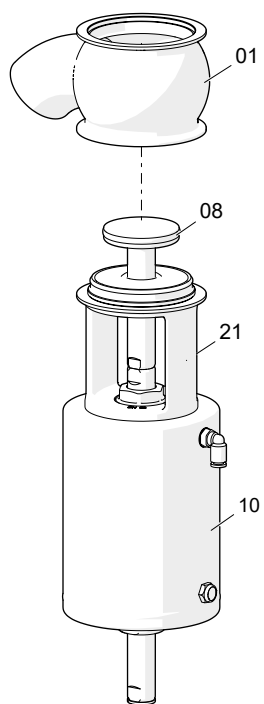

4

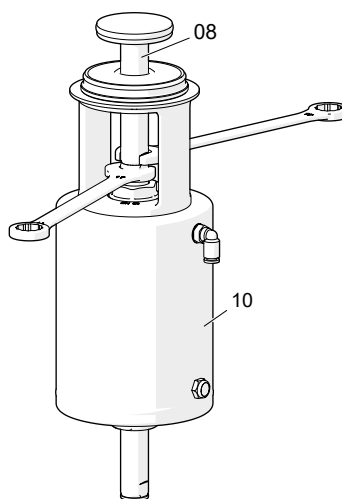

5

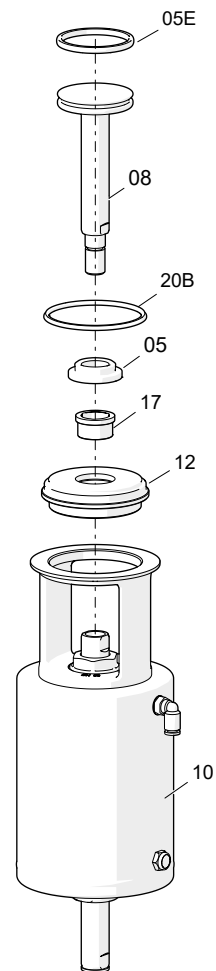

6

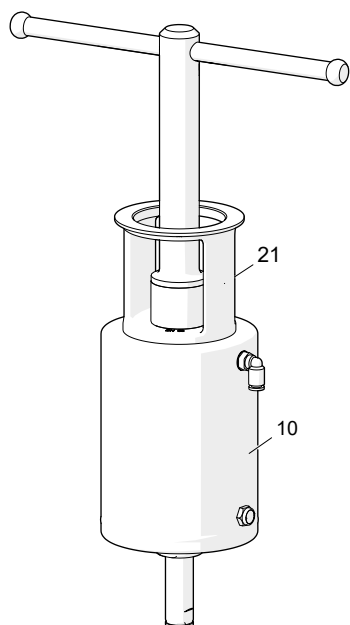

7

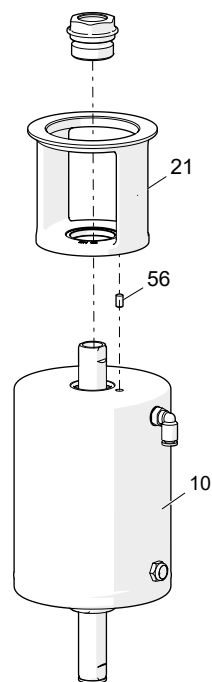

8.5. REPLACING THE SEAT SEAL

1. Put the plug shaft in a vertical position –for example, with a bench clamp- so that the shaft is kept stable and no damage is caused to the mating surface of the conical seal. Do not press the shaft too much if using a bench clamp.
2. Remove the used seal using a screwdriver or a sharp hook-shaped tool. Make sure not to damage the mating surface of the seal.
3. Lubricate the new seat seal with soapy water if necessary to facilitate installation.
4. Insert the seal in the plug shaft seat accommodation so that its edges are inside the accommodation. Preferably, the seal should fit within the part of the section that has the greatest diameter, as shown in the figure.
5. Then, with the help of an appropriate tool (not piercing), press the edge of the seal that has not yet fit into the accommodation, as shown in the figure.
6. This operation should be done around the entire diameter, applying the tool in the sequence **1-2-3-4-5-6-7-8** as shown in the bottom figure. Always press on opposite sides. Once you get to the last step of this sequence, repeat the process until the seal is completely inside the accommodation.
7. Press the seal with your fingers to make sure it will be seated. Make sure there are no parts projecting due to poor positioning of the seal.

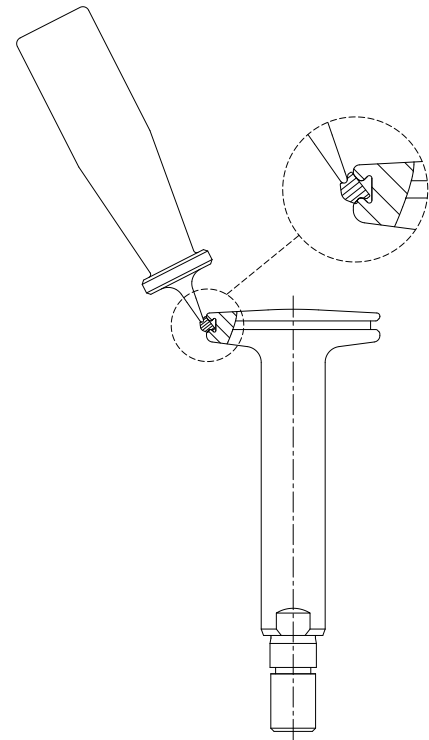

10.248.32.0011

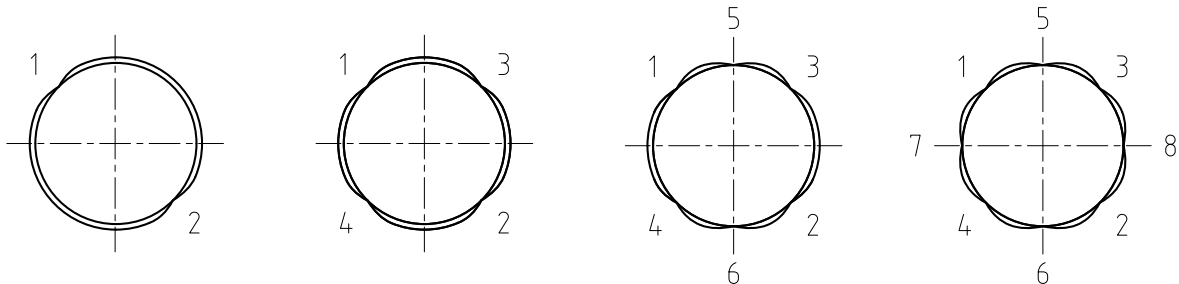

10.240.32.0017

8.6. ACTUATOR CONFIGURATION

The standard configuration of the valves is NC (normally closed).

If the NO (normally open) valve is needed:

1. remove the threaded guide from the lower part of the actuator,
2. remove the plugs and the threaded guide from the upper part of the actuator,
3. turn the actuator 180°,
4. place the plugs and the threaded guide on the upper part of the actuator,
5. place the threaded guide on the bottom part of the actuator.

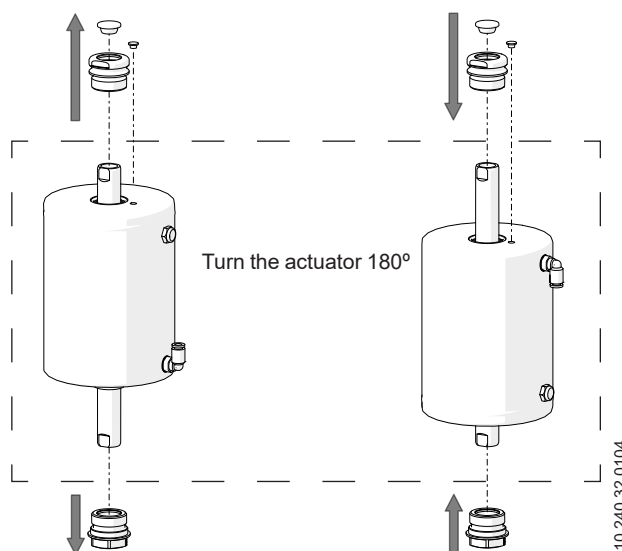

8.7. DISASSEMBLY AND ASSEMBLY OF ADAPTER KIT OF THE CONTROL HEAD



Check that the actuator is without pressure before starting the assembly or disassembly works.

8.7.1. Disassembly

1. Disconnect the compressed air supply.
2. Loosen the screws (24) from the adapter base (13) and separate the control head from the actuator.
3. Remove the cover of the control head.
4. Loosen the screws that join the control head to the adapter base (13).
5. Separate the adapter base (13) from the control head.
6. Remove the O-rings (20A,20B) from the adapter base (13).
7. Unscrew the magnet from the adapter shaft (08).
8. Unscrew the adapter shaft (08) from the actuator shaft.

8.7.2. Assembly

1. Place the O-rings (20A,20B) on the adapter base (13).
2. Remove the plugs from the actuator.
3. Screw the adapter shaft (08) on the actuator shaft.
4. Screw the plug on the adapter shaft (08).
5. Place the adapter base (13) on the actuator and fix it with the screws (24).
6. Remove the cover of the control head.
7. Place the control head and fix it to the adapter base (13).
8. Place the control head.

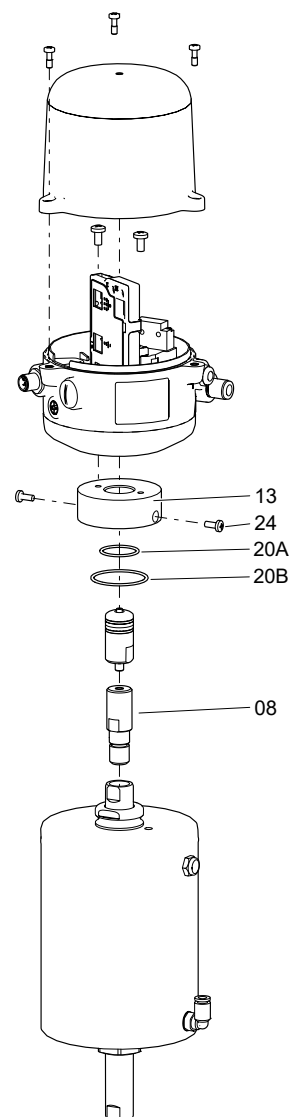

9. Technical Specifications

9.1. VALVE

Maximum working pressure	1000 kPa (10 bar)
Minimum working pressure	vacuum
Opening pressure range	50 kPa - 600 kPa (0,5 bar - 6 bar)
Maximum working temperature	121°C (250°F) EPDM seals (for highers temperatures other grades of seals will be used)

9.2. ACTUATOR

Compressed air pressure	600 - 800 kPa (6 - 8 bar)
Compressed air quality	per ISO 8573-1:2010: <ul style="list-style-type: none"> - <u>Solid particulate content</u>: quality class 3, max. particle dimension = 5 μ, max particle density = 5 mg/m³. - <u>Water content</u>: quality class 4, max. dew point = 2°C. If the valve is used at a high altitude or under low ambient temperature conditions, the dew point must be adjusted accordingly. - <u>Oil content</u>: quality class 5, preferentially oil free, max. 25 mg oil per 1 m³ air.
Compressed air fitting	G 1/8
Compressed air consumption (litres N/cycle of P _{rel} = 6 bar)	

T1		T2		T3		T4	
A/S	A/A	A/S	A/A	A/S	A/A	A/S	A/A
1,1	1,8	2,5	4,0	3,7	6,1	5,6	10,4

9.3. MATERIALS

Parts in contact with the product	1.4404 (AISI 316L)
Other steel parts	1.4301 (AISI 304)
Seals in contact with the product	EPDM (standard) - FPM - HNBR
Internal surface finish	bright polish Ra ≤ 0,8 μm
External surface finish	matt

9.5. SIZES AVAILABLES

DIN EN 10357 serie A (formerly DIN 11850 series 2)	DN 25 - DN 100
ASTM A269/270 (corresponds to OD tube)	OD 1" - OD 4"
Connections	weld, male, clamp

9.4. WEIGHTS

DN	Weight [kg]								
	T1		T2		T3		T4		
	A/S	A/A	A/S	A/A	A/S	A/A	A/S	A/A	
25	4,8	4,1	-	-	-	-	-	-	
40	6,0	5,2	-	-	-	-	-	-	
DIN	50	-	-	9,5	7,9	-	-	-	-
	65	-	-	-	-	14,6	11,9	-	-
	80	-	-	-	-	16,6	13,9	-	-
	100	-	-	-	-	-	-	24,3	20,1

DN	Weight [kg]								
	T1		T2		T3		T4		
	A/S	A/A	A/S	A/A	A/S	A/A	A/S	A/A	
1"	4,8	4,1	-	-	-	-	-	-	
1½"	5,9	5,2	-	-	-	-	-	-	
OD	2"	-	-	9,4	7,9	-	-	-	-
	2½"	-	-	-	-	14,5	11,8	-	-
	3"	-	-	-	-	16,5	13,7	-	-
	4"	-	-	-	-	-	-	24,5	20,3

9.6. DIMENSIONS

9.6.1. Valve with A/S actuator

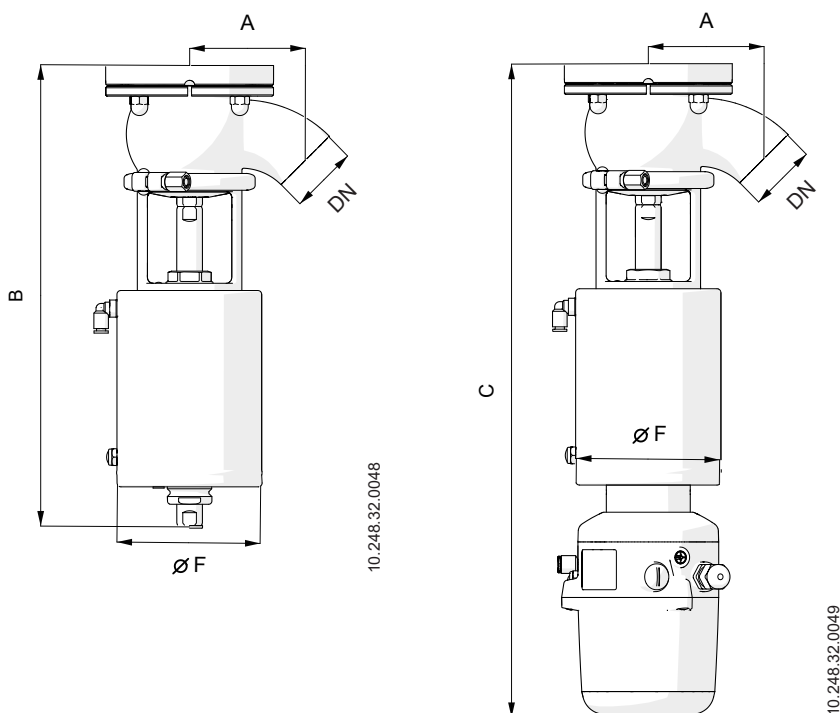

DN	Dimensions [mm]				
	A	B	C	ØF	
25	60	315	440	90	
40	75	330	455	90	
DIN	50	90	395	510	115
	65	110	420	535	140
	80	125	435	550	140
	100	145	470	585	170
	1"	55	310	435	90
OD	1½"	75	330	455	90
	2"	95	395	510	115
	2½"	125	415	530	140
	3"	140	425	545	140
	4"	180	465	585	170

9.6.2. Valve with A/A actuator

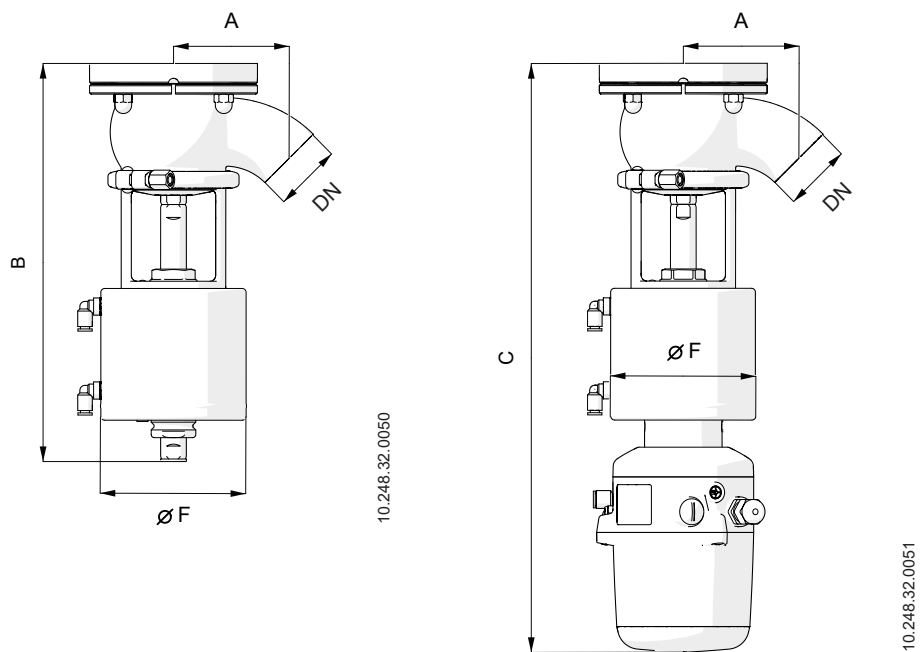

	DN	Dimensions [mm]			
		A	B	C	ØF
DIN	25	60	285	410	90
	40	75	300	425	90
	50	90	345	460	115
	65	110	370	485	140
	80	125	385	500	140
	100	145	420	535	170
OD	1"	55	280	405	90
	1½"	75	300	425	90
	2"	95	345	460	115
	2½"	125	365	480	140
	3"	140	375	495	140
	4"	180	415	535	170

9.7. EXPLODED DRAWING AND PARTS LIST OF THE VALVE

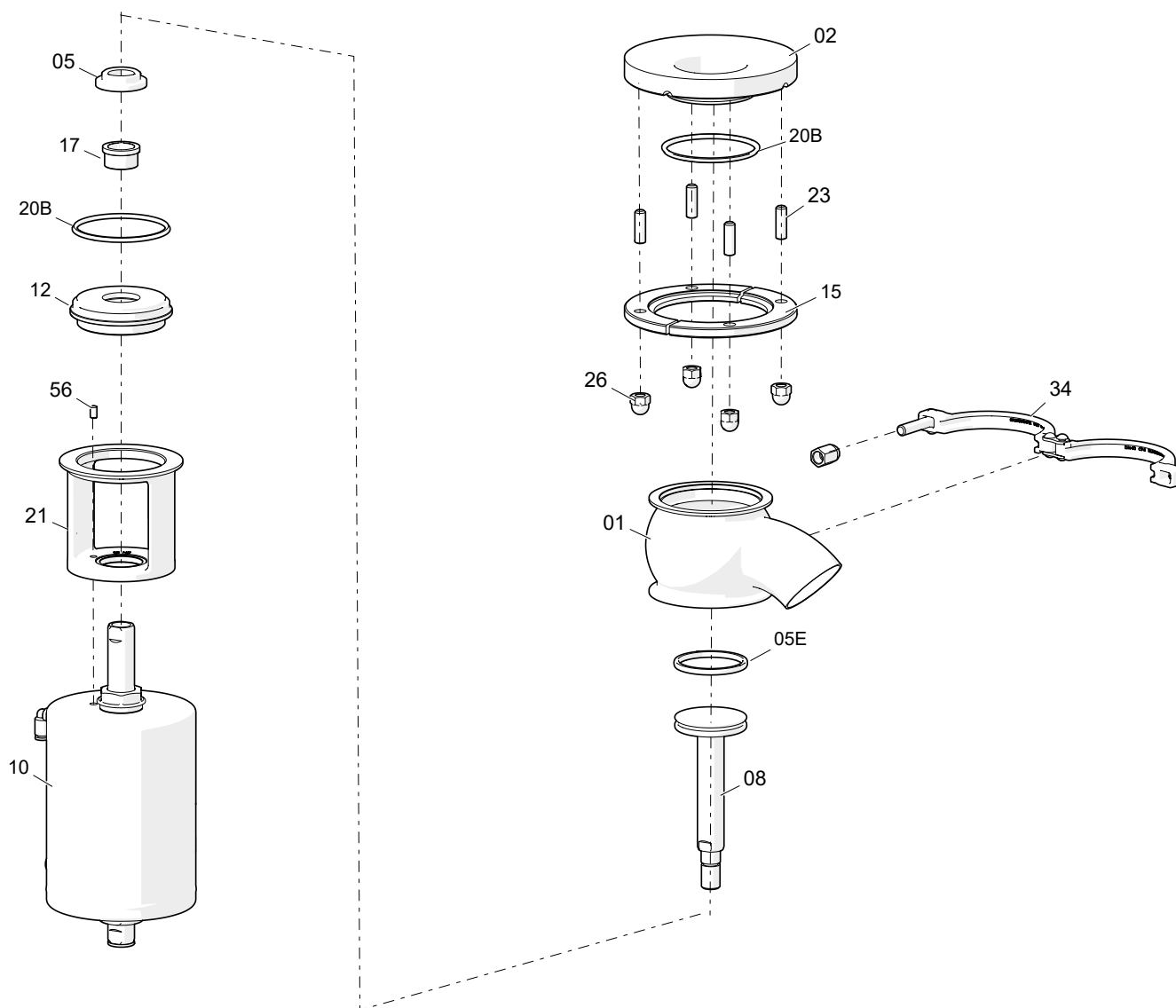

10.248.32.0052

Position	Description	Quantity	Material
01	body	1	1.4404 (AISI 316L)
02	flange	1	1.4404 (AISI 316L)
05	shaft seal ¹	1	EPDM / FPM / HNBR
05E	seat seal ¹	1	1.4404 (AISI 316L)
08	shaft	1	1.4404 (AISI 316L)
10	actuator	1	1.4307 (AISI 304L)
12	body cap	1	1.4404 (AISI 316L)
15	half ring	2	1.4404 (AISI 316L)
17	guide bushing ¹	1	PTFE
20B	O-ring ¹	2	EPDM / FPM / HNBR
21	lantern	1	1.4301 (AISI 304)
23	pin	4	A2
26	blind nut	4	A2
34	clamp	1	1.4301 (AISI 304)
56	pin	1	A2

1) recommended spare parts

How to contact INOXPA S.A.U.:

Contact details for all countries are continually updated on our website.

Please visit www.inoxpa.com to access the information.



INOXPA S.A.U.
Telers, 60 - 17820 - Banyoles - Spain

